



User Manual *for model*

FLOWMAX-90

Condensing water heater
85,000 BTU



⚠ WARNING

If the information in these instructions is not followed exactly, a fire or explosion may result, causing property damage, personal injury or death.

-Do not store or use gasoline or other flammable vapours and liquids in the vicinity of this or any other appliance.

-WHAT TO DO IF YOU SMELL GAS



- Do not try to light any appliance.
- Do not touch any electrical switch; do not use any phone in your building.
- Immediately call your gas supplier from a neighbour's phone. Follow the gas supplier's instructions.
- If you cannot reach your gas supplier, call the fire department.

-Installation and service must be performed by a qualified installer, service agency or the gas supplier.

Installation, operating, commissioning and maintenance instructions.

Water heaters for other than recreational vehicle installation

WATER HEATER OPERATING INSTRUCTIONS

-  **Make sure that the authorized technician who tested the water heater has stamped the guarantee booklet.**
-  **The installation, first start-up, regulation and maintenance operations must be carried out exclusively by qualified personnel (e.g. FLOWMAX authorized Service Centres). Incorrect installation can cause damage to property and injury to persons or animals, for which the manufacturer will not be held responsible.**

During the installation, the technician must carry out the following checks:

- *The data on the data plate must correspond to that of the mains supply networks (gas, electricity, water).*
- *The water heater must be regulated according to its designed use and performance.*
- *The exhaust vent and combustion air intake system must be correctly installed and operational.*
- *The exhaust gas discharge and ventilation systems must comply with the requirements of national and local standards.*

General warnings

- ⦿ If there is any doubt as to whether the appliance has been tested by an authorized technician, do not attempt to start it. All maintenance and gas conversion operations **MUST BE CARRIED OUT BY PROFESSIONALLY QUALIFIED PERSONNEL**, registered in accordance with current legislation.
- ⦿ ***Make sure that the requirements relating to the air intake and ventilation of the room in which the water heater is to be installed have been complied with.***
- ⦿ The water heater is fitted with an antifreeze system. If the water heater is installed in a location where there is a risk of freezing, the anti-freeze system will only come into operation if the power is on and the gas supply valve is open (the frost protection is active even with the ON/OFF switch in OFF position). The manufacturer will not be held responsible for damage to the water heater caused by non-compliance with this instruction.
- ⦿ Should any part of the water heater freeze-up, do not attempt to light it under any circumstances, but instead call the Service Centre immediately.
- ⦿ The appliance's combustion system must be checked annually. This check includes testing the efficiency of the water heater and must be carried out by authorized personnel possessing the qualifications as required by current law.

<p>If the unit fails to re-start after any fault, unplug the unit for 30 seconds, then re-plug in the unit and try to restart with the on/off switch. If the unit fails to restart, call a qualified Technician for service.</p>
--



FOR YOUR SAFETY READ BEFORE OPERATING



WARNING: If you do not follow these instructions exactly, a fire or explosion may result causing property damage, personal injury or loss of life.

- | | |
|---|--|
| <p>A. This appliance does not have a pilot. It is equipped with a direct ignition device, which automatically lights the burner. Do not try to light the burner by hand.</p> <p>B. BEFORE OPERATING: Smell all around the appliance area for gas. Be sure to smell next to the floor because some gas is heavier than air and will settle on the floor.</p> | <p>C. Use only your hand to operate the remote control keypad. Never use tools. If the remote keypad doesn't work, do not try to repair it, call a qualified service technician. Forced or improper repair may result in a fire or explosion.</p> <p>D. Do not use this appliance if any part has been under water. Immediately call a qualified service technician to inspect the appliance and to replace any part of the control system and any gas control which has been under water.</p> |
|---|--|

WHAT TO DO IF YOU SMELL GAS

- Do not try to light any appliance.
- Do not touch any electric switch; do not use any phone in your building.
- Immediately call your gas supplier from a neighbor's phone. Follow the gas supplier's instructions.
- If you cannot reach your gas supplier, call the fire department.

OPERATING INSTRUCTIONS

- | | |
|---|--|
| <ol style="list-style-type: none"> 1. STOP! Read the safety information above before proceeding. 2. Set the thermostat to the lowest setting. 3. Turn off all power to the electrical appliance. 4. This appliance does not have a pilot. It is equipped with a direct ignition device, which automatically lights the burner. Do not try to light the burner by hand. 5. Turn the manual valve located at the gas inlet of the appliance clockwise  to "OFF" | <ol style="list-style-type: none"> 6. Wait (5) minutes to clear out any gas. If you then smell gas, STOP! Follow "B" in the safety information above on this label. If you don't smell gas, go to next step. 7. Turn the manual valve located at the gas inlet of appliance counterclockwise to  "ON" (see Figure 47). 8. Turn on all electric power to the appliance. 9. Set the thermostat to desired setting. 10. If the appliance will not operate, follow the instructions "To Turn Off Gas To Appliance" and call your service technician or gas supplier. |
|---|--|

TO TURN OFF GAS TO THE APPLIANCE

- | | |
|--|--|
| <ol style="list-style-type: none"> 1. Set the thermostat to the lowest setting. 2. Turn off all electric power to the appliance if service is to be performed. | <ol style="list-style-type: none"> 3. Turn the manual valve at gas inlet of appliance clockwise  to "OFF" (see figure 47). |
|--|--|

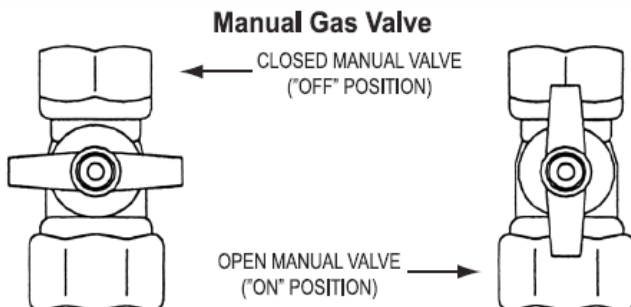

WARNING



Flammable Vapors

FIRE AND EXPLOSION HAZARD

Can result in serious injury or death

 Do not store or use gasoline or other flammable vapors and liquids in the vicinity of this or any other appliance. Storage of or use of gasoline or other inflammable vapors or liquids in the vicinity of this or any other appliance can result in serious injury or death.

Vapors from flammable liquids can explode and catch fire causing death or severe burns.

Do not use or store flammable products such as gasoline, solvents or adhesives in the same room or area near this appliance, or any other appliance or any possible ignition source.

Keep flammable products:

1. far from any possible ignition source,
2. in approved containers
3. tightly closed and
4. out of children's reach

Vapors:

1. cannot be seen,
2. are heavier than air
3. go a long way on the floor
4. can be carried away from other rooms to possible ignition sources by air currents

Water heaters in residential garages must be installed and located, or protected, to avoid physical damage.

Read and follow water heater warnings and instructions. If owner's manual is missing contact the distributor or manufacturer.

DANGER

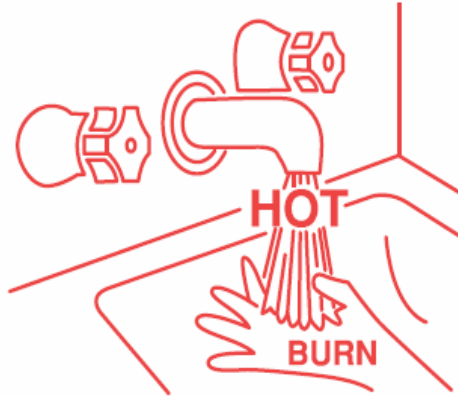

The temperature at which injury occurs varies with the person's age and time of exposure.

The slower response time of disabled persons increases the hazards to them. Never allow small children to use a hot water tap, or to draw their own bath water. Never leave a child or disabled person unattended in a bathtub or shower.

The water heater should be located in an area where the general public does not have access to the temperature control.

Lower water temperatures should be used to avoid the risk of scalding. It is further recommended, in all cases, that the water temperature be set for the lowest temperature which satisfies the user's hot water needs. This will also provide the most energy efficient operation of the water heater and minimize scale formation in the heat exchanger, thus prolonging the life of the unit.

Setting the water heater temperature at 120°F will reduce the risk of scalds. Some states require settings at specific lower temperatures. The table below shows the approximate time-to-burn relationship for normal adult skin.

Hot water temperatures required for automatic dishwasher and laundry use can cause scalds and burns resulting in serious personal injury and/or death.

Table - Risk of Scalds

Temperature Setting	Time to Produce, 2nd, 3rd Degree Burns on Adult Skin
Over 170 °F	Nearly instantaneous
160 °F	About 1/2 second
150 °F	About 1-1/2 seconds
140 °F	Less than 5 seconds
130 °F	About 30 seconds
120 °F or less	More than 5 minutes

To protect against injury, you should install a tempering valve in the water system. This valve will reduce point of discharge temperature by mixing cold and hot water in branch supply lines. Such valves are available from the local plumbing supplier.

WARNING

If the information in these instructions is not followed exactly, a fire or explosion may result, causing property damage, personal injury or death.

-Do not store or use gasoline or other flammable vapours and liquids in the vicinity of this or any other appliance.

-WHAT TO DO IF YOU SMELL GAS

- Do not try to light any appliance.
- Do not touch any electrical switch; do not use any phone in your building.
- Immediately call your gas supplier from a neighbour's phone. Follow the gas supplier's instructions.
- If you cannot reach your gas supplier, call the fire department.

-Installation and service must be performed by a qualified installer, service agency or the gas supplier.

Minimum clearances from combustible construction, 0-inches sides, 0-inches back, 0-inches top.

For closet installation, 0-inches front, or for alcove installation.

This water heater is provided with a pressure relief valve. For safe operation of the water heater, the relief valve(s) must not be removed from its designated point of installation or unplugged.

The temperature and pressure relief valve provided by the manufacturer shall be installed at the time of installation of the heater in the location specified by the manufacturer. Local codes shall govern installation of relief devices. For safe operation of the water heater, the relief valve must not be removed or unplugged.

"Warning"

"This appliance must be installed in accordance with the local codes or, in the absence of local codes, the National Fuel Gas Code, ANSI Z223.1/NFPA 54 or the CSA B149.1, Natural Gas and Propane Installation Code".

SUITABLE FOR WATER (POTABLE) HEATING AND SPACE HEATING

Toxic chemicals, such as used for boiler treatment, shall not be introduced into potable water heater used for space heating. This water heater may never be connected to any existing heating system or component(s) previously used with a non potable water heating appliance.

"For operation at outlet water temperatures not in excess of 180°F (88°C)"

If you smell gas....

- ➔ **DO NOT ACTIVATE ANY ELECTRIC SWITCHES, TELEPHONES OR ANY OTHER DEVICE THAT MAY GENERATE ELECTRICAL DISCHARGES OR SPARKS.**
- ➔ **OPEN DOORS AND WINDOWS IMMEDIATELY TO CREATE A CURRENT OF AIR THAT WILL RAPIDLY CLEAR THE ROOM.**
- ➔ **CLOSE ALL GAS TAPS AND VALVES.**
- ➔ **CALL FOR PROFESSIONALLY QUALIFIED PERSONNEL.**

Water heater controls - Control panel

LEGEND

1. ON/OFF SWITCH
2. HEATING TEMPERATURE CONTROL KNOB
3. D.H.W TEMPERATURE CONTROL KNOB.
4. D.H.W TEMPERATURE DISPLAY BUTTON. (KEEP PRESSED FOR 5 SECONDS TO DISPLAY OUTSIDE TEMPERATURE -ONLY WITH OPTIONAL OUTDOOR SENSOR)
5. SERVICE BUTTON.
6. SUMMER, WINTER OR SUMMER/WINTER MODE SELECTION BUTTON.
7. TERMINAL BOARD FOR EXTERNAL WIRING.
8. TEMPERATURE, ERROR CODE AND OPERATING STATUS DISPLAY.

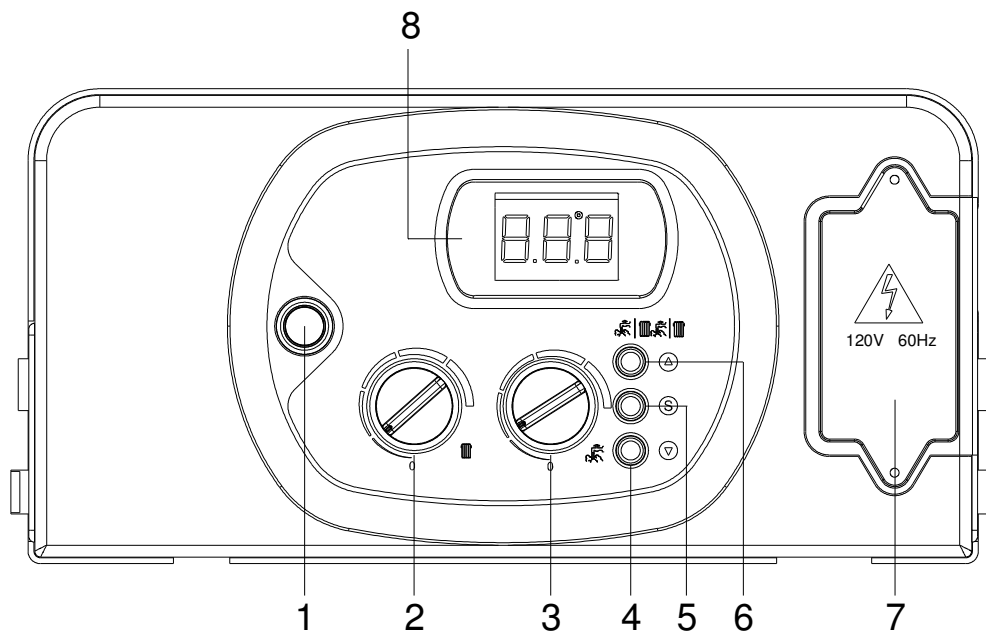
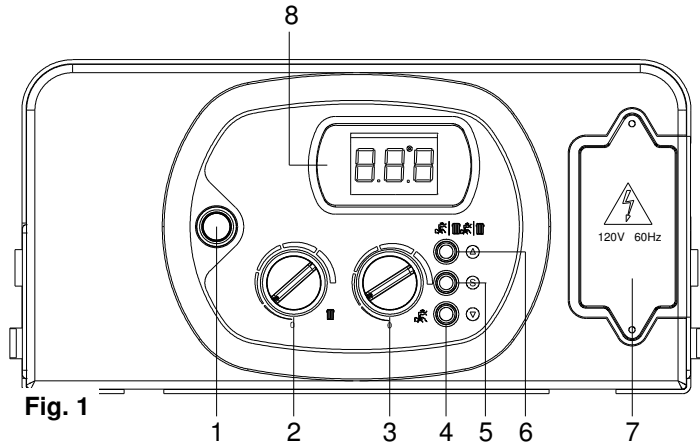



Fig. 1

Starting - up the water heater

- Open the gas Isolation valve located under the water heater.
- Switch on the water heater by placing the ON/OFF switch (1) in the **ON** position (see “Control panel”).
- The water heater will light automatically (with the WINTER mode selected and room thermostat connected).
- Check that there are no flashing numbers on the display **8** (see error codes). If code **H2O** appears on the display **8** this denotes that there is no water in the water heater. Consequently, fill the system as described in section “Filling the system”.





■ “SUMMER” mode

To switch water heater operation to “SUMMER” mode, press button **6** (see fig. 1). The water heater will only work for the D.H.W system. The “SUMMER” mode setting of the water heater is signalled by the symbol  lit continuously on the control panel.



The automatic ignition system will light the burner every time there is a demand for domestic hot water. In this case, the symbol  on the control panel will flash.



■ “WINTER” mode

To switch water heater operation to “WINTER” mode, press button **6** (see fig. 1). The water heater will only work for the central heating system. The “WINTER” mode setting of the water heater is signalled by the symbol  lit continuously on the control panel.

The automatic ignition system will light the burner every time there is a demand for room heating. In this case, the symbol  on the control panel will flash.

■ “SUMMER-WINTER” mode

To switch water heater operation to “SUMMER/WINTER” mode, press button **6** (see fig. 1). The water heater will work for both central heating/D.H.W systems. The “SUMMER/WINTER” mode setting of the water heater is signalled by the symbols   lit continuously on the control panel.

The automatic ignition system will light the burner every time there is a demand for room heating or domestic hot water, the functioning is signalled by the symbols   flashing continuously on the control panel.

■ Regulating the heating temperature

The heating temperature is regulated by knob **2** (see fig.1).

- Rotating the knob anticlockwise reduces the temperature.
- Rotating the knob clockwise increases the temperature.
- The range of temperature settings for the central heating runs from a minimum of 30°C to a maximum of 80°C, or, in the case of low temperature operation, from a minimum of 25°C to a maximum of 59°C.

■ D.H.W temperature control

The domestic hot water temperature is regulated by knob **3** (see “Control panel”).

- Rotating the knob anticlockwise reduces the temperature.
- Rotating the knob clockwise increases the temperature.
- The range of temperature settings for the domestic hot water runs from a minimum of 35°C to a maximum of 60°C.

■ Topping-up the system with water

The water pressure in the central heating circuit must be checked during the entire period of operation of the water heater. In this respect, the reading on the pressure gauge **M** (fig. 2), located on the lower part of the water heater, must not be less than 1 bar.

If there is insufficient water in the water heater, the code **H2O** will flash on the display (see fig 1).

To bring the system back up to pressure, open the external filling tap **R** (fig.2) and use the pressure gauge **M** (fig. 2) to check that the system pressure reaches 1 bar and that the code H2O lights up.

When the operation is complete, close the fill tap.

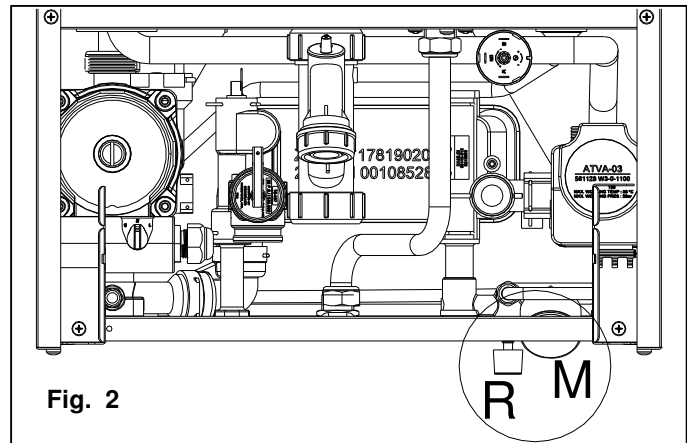

Diagnostics – Error codes:

This paragraph contains a list of error codes that the water heater may generate on the display **8** (see “Control panel”) together with the relative indications and the operations that the user can carry out to reset the water heater.

⚠ If the problem re-occurs after the following actions have been taken, call an authorized Service Centre.

E01 Ionization block

Code **E01** lit continuously on the display.

- Check that the gas valve on the water heater and gas meter are open and that there is gas in the mains supply (or in the tank).
- Switch off then switch on the appliance using switch **1** (see “Control panel”) on the control panel.
- When the error code on the display disappears, the water heater will restart.

If the problem persists, **call the Service Centre.**

E02 Safety Thermostat tripped

Code **E02** lit continuously on the display. **Call the Service Centre.**

E03 Exhaust Vent Thermofuse tripped

Code **E03** lit continuously on the display. **Call the Service Centre.**

h2o Water Pressure Switch tripped

Code **H2O** lit continuously on the display.

- Check the water pressure in the central heating circuit. The reading on the pressure gauge **M** (see fig. 2), located on the lower part of the water heater, must not be less than 1 bar.
- If the pressure is less than 1 bar, top-up the system as described in paragraph “Filling the system”.
- The water heater will restart automatically.

If the problem persists, **call the Service Centre.**

E05 Heating Sensor malfunction

Code **E05** lit continuously on the display. **Call the Service Centre.**

E06 D.H.W Sensor malfunction

Code **E06** lit continuously on the display. **Call the Service Centre.**

E16 Electric Fan Malfunction

Code **E16** lit continuously on the display. **Call the Service Centre.**

E22 Parameter programming request

Code **E22** lit continuously on the display. **Call the Service Centre.**

E35 Flame Detection Malfunction

Code **E35** lit continuously on the display. **Call the Service Centre.**

E42 Fan Speed P.C.B. malfunction

Code **E42** lit continuously on the display. **Call the Service Centre.**

N.B. If the water heater is to be left unused for a long period of time, the user must do one of the following:

- *Make the water heater safe* by disconnecting all the power supplies (electricity and gas), and draining the heating system and the condensate trap.
- Leave the water heater in *standby*, leaving the electricity and gas supplies connected and, consequently the anti-freeze function.



FLOWMAX Technologies

71 Innovation Drive, unit 8 & 9
Vaughan, Ontario, L4H 0S3
Tel: 905-264-1414
Fax: 905-264-1147
E-mail: info@flowmaxtechnologies.com
Web Site: www.flowmaxtechnologies.com